

# Replacing Batteries on your Wireless Photoelectric Smoke & Temperature Alarm

This information is provided so that, for your convenience, you can swap out batteries in a wireless device in your Smart Home Security System.

- 1) BEFORE you start tampering with your device, please call our Monitoring Center at (866)406-5787 to put the system in "test" mode. You will need your password to verify it is you, and not an unauthorized person calling. They will put the alarm in a suspended mode so that your activities will not set off a false alarm.
- 2) Using the below diagrams and instructions, you should be able to open the cover of the device and swap old batteries for new.
- 3) Please call our local office at (865)474-9495 if you have any questions or problems.

## WHEN TO REPLACE THE BATTERIES

When the batteries are low, the unit extinguishes its LED and chirps every 45 seconds until the batteries are replaced. The low battery trouble chirps can be silenced for 24 hours by pressing the TEST/SILENCE button. Battery life is a minimum of one year, and varies depending on how often the unit is tested.

## REPLACING THE BATTERIES

Use only 3V lithium batteries listed on the battery compartment cover.

1. Remove the unit from the mounting base, grasp the unit and turn it counterclockwise approximately 15 degrees.
2. Slide the battery compartment cover away from the smoke alarm to unsnap it and lift it off. See Figure 2.
3. Remove the batteries and dispose of them properly.
4. Observing correct polarity, insert two new 3V lithium batteries into the battery compartment and replace the cover.
5. Reattach the unit to the mounting base. See *Installation*, Step 6.
6. Test the system.

## LED FUNCTIONS

**Flashing** — Flashes every 9 seconds to indicate normal operation.

**On** — Detects smoke

**Off** — Trouble or maintenance is required.

**NOTE:** Each of these devices requires two 3V lithium batteries. Look, or ask, for CR123A batteries at your favorite store.

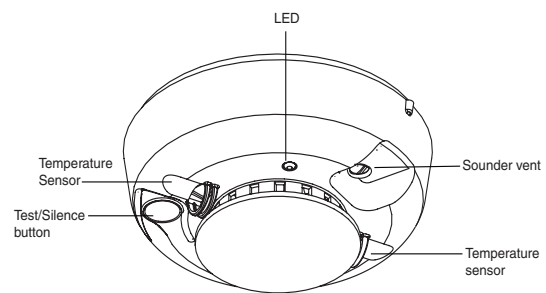

Figure 1. Smoke Alarm Features

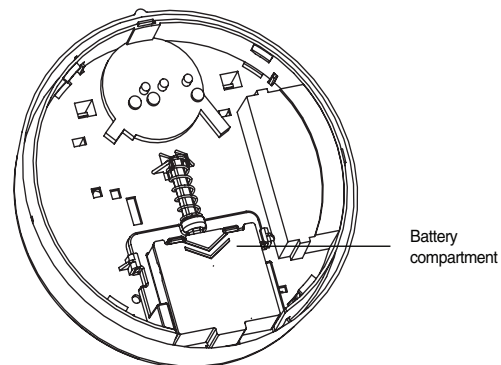

Figure 2. Battery Compartment

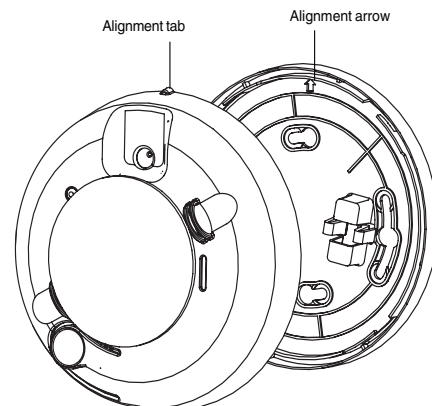

Figure 3. Smoke Alarm-to-Base Alignment



"In GOD we trust, all others we monitor."

11426 Kingston Pike • Farragut, TN 37934

(865) 474-9495